

Implementation of Reverse Engineering Method in Pre-Treatment Area for Designing Jug Cleaning Workspace

1st Shafa Jasmina Anggita Putri
Faculty of Industrial Engineering
Telkom University
Bandung, Indonesia

shafaajsmn@student.telkomuniversity.a
c.id

2nd Ilma Mufidah
Faculty of Industrial Engineering
Telkom University
Bandung, Indonesia

ilmamufidah@telkomuniversity.ac.id

3rd Sri Martini
Faculty of Industrial Engineering
Telkom University
Bandung, Indonesia

martini@telkomuniversity.ac.id

Abstract - Drinking water is one of the most essential things that people needed for life. Without mineral water, human body will have dehydration and it can create an effect to disorders and infections to the urinary tract. Improved water supply and sanitation, as well as better water resource management, can boost countries' economic growth and contribute significantly to poverty reduction. In Indonesia, different varieties of drinking water are available for purchase by the public and are a necessity for daily life. For instance, there are bottles with capacities of 250 ml, 600 ml, etc., and a jug with a 19 L or even smaller capacity. However, this is where the issues are identified. There are some jugs that fall under the minor defect and major defect categories and are not classified for reuse. The jug's minor flaw is that it can still be used after a few polishes using the chosen procedure. For instance, a crack that is smaller than the designated size or a dirty jug. The jug's major flaw, however, prevents it from being used any longer because it goes against the explicitly stated company policies.

Keywords— Drinking water, Jug, Cleaning Machine, Product Development, Reverse Engineering

I. BACKGROUND

Drinking water is one of the most essential things that people need for life. Without mineral water, human body will have dehydration and it can create an effect to disorders and infections to the urinary tract. Water that is safe and easily accessible is essential for public health, whether it is used for drinking, domestic use, food production, or recreation. Improved water supply and sanitation, as well as better water resource management, can boost countries' economic growth and contribute significantly to poverty reduction. The Guidelines define safe drinking water as not posing any significant risk to health over a lifetime of consumption, including different sensitivities that may occur between life stages. Infants and young children, the elderly, and the disabled are the most vulnerable to waterborne disease, especially when living in unsanitary conditions. Those who are generally at risk of waterborne illness may need to take additional precautions, such as boiling their drinking water, to protect themselves from waterborne pathogens. All normal domestic purposes, such as drinking, food preparation, and personal hygiene, require safe drinking water. The Guidelines apply to packaged water and ice meant for human consumption. However, higher quality water may be required for some special purposes, such as renal dialysis and contact lens cleaning, or for specific purposes in food production and pharmaceutical use. The Guidelines may not

be appropriate for aquatic life protection or for certain industries. Based on Indonesian's Minister of Health regulations, the water can be drunk if it is through processing or without processing that meets health requirements and can be drunk directly.

PT. Tirta Investama is a company that is engaged in the manufacturing of the AQUA drinking water, which is technically be the subsidiary of PT. Danone, that is known as the first and biggest mineral water drink in Indonesia. One of PT. Tirta Investama branch is located in Subang, West Java, that is assisting in the production of the 600 ml bottle and 19 L jug packaging. The jugs are treated before being re-distributed to the public in accordance with the drinking water policies already established by PT. Danone.

Formerly, operators for the pre-treatment were feeling sore, especially for the wrist and waist because of the time for the jug cleaning that is filled of mose that practically makes the cleaning came difficult, and as it is done per-shift, the operators must seat down approximately three until four hours until the shift changed until currently a machine that was self-built to help clean the dirty jug in a matter of seconds is the main focus. However, the machine still needs to be improved in order to accommodate anthropometric measurements and human concerns, which will also help the workers feel comfortable while using the machine. The jug machine is called GOEL, an automatic cleaning jug tool that is designed to make cleaning faster and more efficient than before. GOEL machine was made because of the previous pre-treatment washing has been done manually.



FIGURE 1
(Pre-Treatment Area)

The machine was already going through the fulfilment treatment with the risk analysis around the safety, quality, cost, delivery, motivation, and environment. Even though the cleaning process for the jugs was renewed, there are still

things that can be improved based on what was observed on the field. An interview was being asked to the operators as they commented, the machine still has room for improvement. A few examples include making the operators' seats more comfortable while using the machine, changing the way the electricity is run to increase safety, and adding extra components like a garbage can to the machine. With a precise brush for cleaning the inside of the jug, the moss can also be removed more easily.

Following the interview with the operators, the pre-treatment area's surroundings were also examined and recorded based on field observations and the operators' feedback on the newly-being-developed machine. An observation checklist was created to list the assertions that are visible to the unaided observer in order to create a basic resume about the observation. An observation checklist is a crucial tool for keeping track of field notes and is a means of gathering data for research projects by watching what is happening and why. Therefore, the observation checklist has been concluded:

TABLE 1
(Observation Checklist)

OBSERVATION CHECKLIST				
NAME OF THE RESEARCH: Checking on the pre-treatment workers for the jug cleaning machine				
Date: July 13th, 2023				
Observer: Shafa				
No	Criteria	Yes	No	Observations
1.	The workspace has a good placement.		✓	The placement for the pre-treatment is near of the visualizer and to the primary washing machine. However, the place is quite not suitable and safe.
2.	The workspace has a sufficient light	✓		The pre-treatment area has a sufficient light to help the workers on the process.
3.	The process using a recycle water and reducing the water needs.	✓		The pre-treatment area uses a recycle water for the process.
4.	The jug cleaning machine has a sufficient machine for the pre-treatment process.		✓	The jug is still everywhere which is waiting to be cleaned by only two employees per-shift.
5.	The jug cleaning machine can clean the jug fast.	✓		The jug cleaning machine cleans the jug fast, faster than before the machine created.
6.	The jug cleaning workspace has a comfort that is given to the employees.		✓	The employee's posture did not show that their comfortable with the state.
7.	The jug cleaning machine is according on the safety measurement.	✓		The employee operates the jug cleaning machine safely.

Besides the interview, an observation has taken into place where the workspace for the pre-treatment area can be improved with appropriately placed in the space. Aside from that, the ergonomics factor for the operators can still be improved, as the operators stated that the chair is not comfortable enough to sit in for a five to six hour per-shift. Hence, the equipment and working environment can be improved to improve the operators' comfort and health.

After an interview and observation being concluded, NASA-TLX also becoming a supporting data which have the data for the employee's workload. NASA-TLX is one of the applicated method for collecting on the workers need. NASA-TLX has its own form to proceed the data that has been collected from the workers about the ergonomics statements depends on the six factors: mental demand, physical demand, temporal demand, frustration level, performance, and effort.

TABLE 2
(NASA-TLX Calculation)

No	Name	Aspect	Rating	Weighted	WWL	Score	Indication
1.	Tono	MD	50	1	750	50	High
		PD	50	3			
		TD	50	4			
		PO	50	3			
		EF	80	1			
		FR	40	3			
2.	Engkus	MD	50	2	900	60	High
		PD	100	3			
		TD	50	5			
		PO	50	3			
		EF	50	2			
		FR	50	0			
3.	Giwa	MD	65	1	1045	70	High
		PD	60	3			
		TD	80	2			
		PO	70	3			
		EF	70	5			
		FR	80	1			
4.	Proy	MD	70	1	930	62	High
		PD	75	2			
		TD	70	3			
		PO	60	4			
		EF	65	4			
		FR	70	0			
5.	Dedi	MD	70	0	915	61	High
		PD	65	2			
		TD	60	4			
		PO	55	3			
		EF	60	4			
		FR	70	2			
6.	Wildan	MD	60	1	940	63	High
		PD	55	2			
		TD	60	4			
		PO	70	3			
		EF	60	3			
		FR	70	2			

According to the data obtained, six employees scored 'High', indicating that quick action is required to be proceed.

From the problems, it can be identified that the problem definition can be formulated by:

1. How to improve the suitable jug cleaning machine to be used for the people who use it?
2. How to re-design the jug cleaning machine to help the workers to have a comfortable state by the process?

As for the objectives are:

1. Improve the suitable aspects of the jug cleaning machine for the workers.
2. Re-design the machine to improve the comfortable state process for the workers.

II. LITERATURE REVIEW

A. Product Design

Based on Ulrich (2020), the design function plays the lead role in defining the physical form of the product to best meet customer needs. The design function includes engineering design which is mechanical, electrical, software, etc., and industrial design by aesthetics, ergonomics, and user interfaces. Product design needs to look at the environment that has been going around before the product developed.

B. Human Factors Ergonomics (HFE)

Human Factors and Ergonomics (HFE) is a study of the interactions between people and technology and the factors that affect the interactions (Bridger, 2018). Its objective is to ensure the system's functioning so that defined people with defined skills and knowledge can carry out defined tasks, using defined equipment, to defined standards under defined conditions. HFE is never used exclusively. HFE experts collaborate with project and management teams to evaluate

and reduce risk in current systems or to create new systems or products.

C. Mental Workload

Based on Hancock and Caird (1993) and Wilson and Rajan (1995), mental workload presents human factors researchers with something of a paradox because it is certainly a crucial factor in determining performance. There are four main classes of mental workload measurement techniques: primary task, secondary task, subjective, and physiological. Mental workload has been a promising development to increase the effectiveness of a job.

D. NASA-TLX (National Aeronautics and Administration Task Load Index)

NASA-TLX is one of the methods that is used for measuring the workload that is have been through by a worker in one activity for its job. From the viewpoint of the person who provided the rating, the contribution of each of the six factors to the workload of the particular task is to be assessed. When calculating the overall workload score, the ratings of the factors considered to be most crucial in generating the workload of a task are given more weight. This method is developed by Sandra G. Hart and Lowell E. Staveland in the year of 1981. The appearance of the method is based on the difficulties of the job, time pressure, activity type, physics force, performance, frustration level, stress, and fatigue. From these factors, it is simplified into mental demand (MD), physical demand (PD), temporal demand (TD), performance (P), effort (E), and frustration level (FR).

E. Reverse Engineering

Reverse engineering is known for the applicability to new designs of old parts. It is a top-down reinvention process, while machine design is bottom-up creation process (Wang, 2010). Reverse engineering involves measuring and analyzing an existing, potentially worn-out component to create a design drawing for potential future production. Reverse engineering is well known for assisting in general science because it can be used in any field. Reverse engineering is primarily used to recreate a mirror image of the original patent. Reverse engineering and re-design methodology is first discovered by Wood, Jensen, and Otto which have three phases of reverse engineering: modeling, analysis, and re-design.

III. METHODOLOGY

A. Problem Solving Systematics

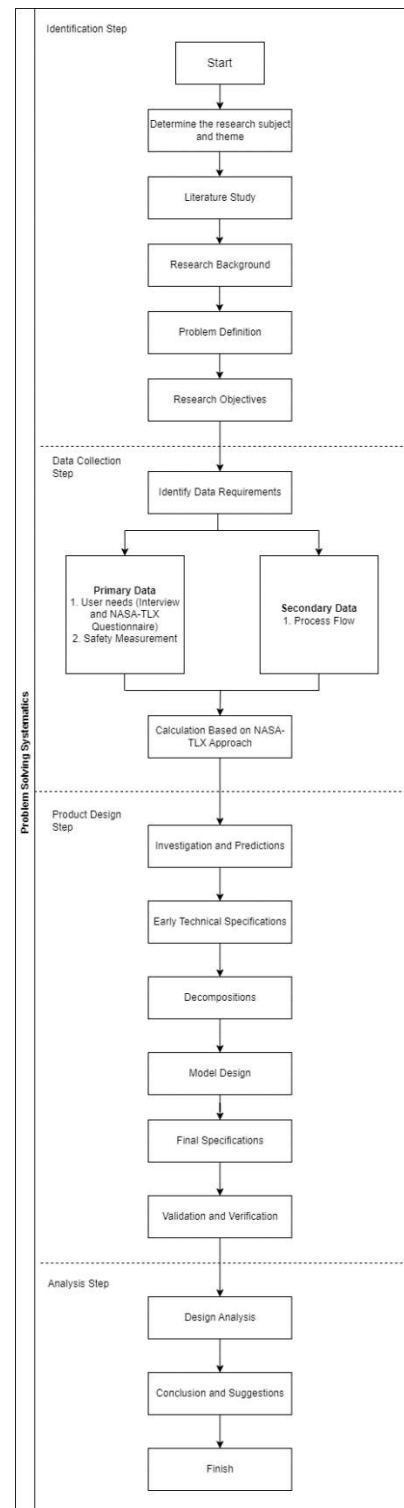

FIGURE 2
(Problem Solving Systematics)

From the beginning as the identification step, the research subject and theme has been concluded, which is bringing on the topic for the jug cleaning workspace in the pre-treatment area which is focusing on the employees. After collecting the literature study and make a research background of the purposes research, the problem has been defined which can put into the objectives to how it begins.

The second step is data collecting, which includes both primary and secondary data. The key data includes

user demands gathered through interviews and the NASA-TLX questionnaire, as well as safety measurements for personnel safety. Next, there is a secondary data that supports the primary one, the process flow, to know where the pre-treatment procedure takes place.

The next step is product design, which begins with the re-modeling of the product. The inquiry and projections are based on the previously conducted interviews and observations. Following completion, reverse engineering begins with the decomposition of the product. The interviews will generate a need statement that will assist the product in being improved based on employee needs, which leads to model design from reconstructions with the support of concept development for each option combination. Following the completion of the final design, the validation and verification procedure begins. Finally, the design will be analyzed to reach a conclusion and make ideas.

IV. RESULT AND DISCUSSION

A. Data Description

1. Need Statement

The need statement has been concluded from the interview that was given to the operators and the observation that has been conducted on the place. And from two operators, the customer needs are being ranked based on the needs and supportive circumstances.

TABLE 3
(Customer Needs Rating)

Rating	Customer Needs
**	The jug cleaning machine improves the jug cleaning process.
**	The jug cleaning machine cleans many dirty jugs.
***	The jug cleaning machine can be adjusted based on the employee.
***	The jug cleaning machine has a safe design and placed in safe distance.
***	The jug cleaning machine can provide comfort to the employee who seat on the chair.
**	The jug cleaning machine has a more safety in any aspects.
**	The jug cleaning is useful for cleaning on the jugs on pre-treatment process.
***	The jug cleaning machine efficiently cleans on the moss and dirt inside the jug.
**	The jug cleaning machine efficiently have a bin.
*	The jug cleaning can have an efficient maintenance regularly.

And the picked need statement concluded below:

TABLE 4
(Need Statement)

No	Need Statement
1.	The jug cleaning machine can be adjusted based on the employee.

2.	The jug cleaning machine has a safe design and placed in safe distance.
3.	The jug cleaning machine can provide comfort to the employee who seat on the chair
4.	The jug cleaning machine efficiently cleans on the moss and dirt inside the jug.
5.	The jug cleaning machine efficiently have a bin.

B. Design Process

a. Existing Product

The reverse engineering process has a broad range of applications. With this, the product is being redesigned and mechanical elements are being repaired based on the need statement and NASA-TLX aspects that have been agreed upon. The scanning on the complex that is being divided into parts is advantageous for reverse engineering.



FIGURE 3
(Existing Machine)

b. Need Statement Identification

From the previous stated need statement, the need statement identification to the product attributes convection can be determined.

TABLE 5
(Need Statement to Product Attributes)

No.	Need Statement	Product Attributes
1	The jug cleaning machine can be adjusted based on the employee.	The jug cleaning machine has a marketplace plastic chair.
2	The jug cleaning machine has a safe design and placed in safe distance.	The jug cleaning machine do not have a safety aspect to protect on the machine from the electricity, the floor is also wet from the pre-treatment process, and the product is quite far from the safe design.
3	The jug cleaning machine can provide comfort to	The jug cleaning machine has a

	the employee who seat on the chair	marketplace plastic chair.
4	The jug cleaning machine efficiently cleans on the moss and dirt inside the jug.	The jug cleaning machine use a manual marketplace brush for cleaning the jug.
5	The jug cleaning machine efficiently have a bin.	The jug cleaning machine use a marketplace garbage bin.

c. Functional Analysis

Following the conversion to product attributes, future forecasts are required to develop the machine based on employee needs. It requires a feature for the plan design, thus here are the product's future predictions:



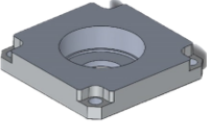
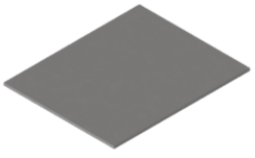

TABLE 6
(Product Attributes to Functional Predictions)





No.	Product Attributes	Functional Predictions
1	The jug cleaning machine has a marketplace plastic chair.	The jug cleaning machine has a proper ergonomic and comfort chair.
2	The jug cleaning machine near from the electrical wire and do not have a safety aspect to protect on the machine from the electricity, the floor is also wet from the pre-treatment process.	The place for jug cleaning machine being properly designed for the electrical resources.
4	The jug cleaning machine use a manual marketplace brush for cleaning the jug.	The jug cleaning machine has an integrated system for the semi-automatic brush.
5	The jug cleaning machine use a marketplace garbage bin.	The jug cleaning machine has an addition of the garbage bin attached on the product.







d. Decomposition Analysis

Machine decomposition helps to achieve a better understanding upon the machine and the method that is used for the product. The product be 'destroyed' as the effect of the components be involved. Based from the picture above, as for the outer, the machine can be split into x parts. It is mentioned to the table below:

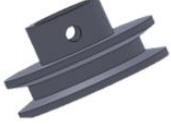
TABLE 7
(Split Parts)

No.	Part Name	Image
1.	Frame Hollow SS 30x30	
2.	Cover Gallon Plate	
3.	Motor Holder Plate	
4.	Bulkhead Plate	
5.	House Motor Plate	
6.	Swing Door Plate	

7.	Motor	
8.	Outer Teflon	
9.	Inner Teflon	
10.	Plate 3mm	
11.	Plate 5mm	

		
12.	Pulley	
13.	Jug Holder	
14.	Spring	
15.	Tube 30mm	
16.	Garbage bin	
17.	Steel barstool chair	

In the decomposition of the product, the revocation experiments by steps are needed to look at the product further. Several components will determine the effect if its losses for the product. The table below shows the decomposition process:

TABLE 8
(Split Part Explanation)

Sub-Assembly	No .	Component Name	Component Revocation Effect	Component Function Result
Lower Desk	1.	Frame Hollow SS 30x30	The product does not have a lower frame to hold and place the inner parts.	The component is to upstand the lower frame of the machine.
	2.	Motor Holder Plate	The product does not have a place to put on the motor for the machine.	The component is to hold the motor of the machine.
	3.	Cover Gallon Plate	The product does not have an upper frame for supporting the lower.	The component is to hold on the upper of the product.
	4.	Bulkhead Plate	The product does not have an exact barrier for the upper space and the motor.	The component is to limiting the motor and the upper machine.
Upper Desk	5.	House Motor Plate	The part does not have a significant effect for the whole product.	The part does not have a significant effect for the whole product.
	6.	Swing Door Plate	The product does not have an opener for checking on the rotator and the motor (inner machines).	The component is needed be a door to open and see the rotator and motor inside.
	7.	Outer Teflon	The rotator could be	The component

			openly shown because there is not any cover and could make the components shattered.	is needed to cover on the rotator.
	8.	Motor	The product cannot be run to clean on the jug.	The component is needed as a psyche of the product to clean the jug.
	9.	Inner Teflon	The rotator cannot hold on the jug to stay on the position.	The component is needed to make the jug to stay on the position.
	10.	Plate 3mm	The rotator does not have a base for holding the whole rotator component .	The component is needed to hold on the component s as it makes the jug rotator.
Jug Rotator	11.	Plate 5mm	The rotator does not have a base for holding the whole rotator component .	The component is needed to hold on the component s as it makes the jug rotator.
	12.	Pulley	The rotator does not have a base for holding the 1whole rotator component and to enter the hole from the rotator holder plate.	The component is needed to hold on the component s as it makes the jug rotator and to enter the hole from the rotator holder plate.
	13.	Jug Holder (Part)	The rotator cannot hold on the jug to stay	The component is needed to make the

			on the position.	jug to stay on the position.
	14.	Spring	The jug cannot be entered with a flexible position for the rotator.	The flexible component for the jug to enter the rotator.
	15.	Tube 30mm	The rotator does not have any stand for the jug to enter.	The component is needed to be the stand for the rotator and the main core for the unit to rotate.
Additional 1	16.	Garbage bin	The product does not have spot to throw in the moss and garbage as the result from the jug cleaning.	The product does not have spot to throw in the moss and garbage as the result from the jug cleaning.
	17.	Steel Barstool chair	The employee cannot have a comfortable position to clean the jug.	The component is needed to make the employee place an ergonomic spot for cleaning the jug.

workers to work and the jug cleaning machine works more efficiently than the initial machine even though a slight of improvement, which result in make the jug to be cleaned efficiently and make the workers comfortable with the posture.

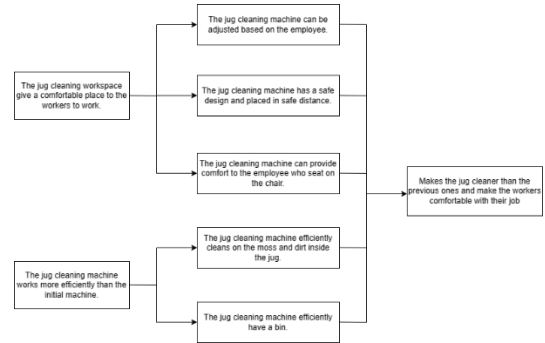

FIGURE 5 (Part Decomposition)

After the view of the black box has been determined, the decomposition starts by placing the initial plans with the need statement that is categorized, which made in a result for making the jug is cleaner than the previous ones before the machine being improve and make the workers comfortable with their job.

b. Search Internally & Externally

After the parts have been decomposed, the need statements are being arranged and pick on the options that could change the parts for the shape, material, and other additional.

TABLE 9 (Search Internally & Externally)

Function	The jug cleaning machine can be adjusted based on the employees.	The jug cleaning machine has a safe design and placed in safe distance.	The jug cleaning machine can provide comfort to the employee who seat on the chair	The jug cleaning machine efficiently cleans on the moss and dirt inside the jug.	The jug cleaning machine efficiently have a bin.
Option 1	Manual Brush Hanger	Rounded Corner	Monobloc Chair	Manual Brush (Without Rotator)	Separated Bin
Option 2	Automatic Brush Hanger	Non-rounded corner	Swivel Chair	Manual Brush (With Rotator)	Merger Bin
Option 3			Adjusted Barstool Chair	Adjusted Automatic Brush	
Option 4			Dining Chair		
Option 5					

C. Modeling

A product concept is a rough description of the product's technology, functioning principles, and form.

a. Black Box and Part Decomposition

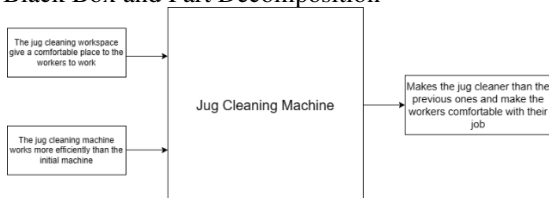

FIGURE 4 (Black Box)

From the picture above, it can be described the black box of the jug cleaning machine which is having two main ideas, the jug cleaning workspace give a comfortable place to the

If the possibilities are still retained, the concept will have a lot of superfluous combinations that could have been removed. The needs that are lifting the upcoming option are still holding and have deleted the possibilities that could have been removed. Here is the table for the removed options, which are marked in red, as well as the following table below is the reason why the options being removed:

TABLE 10
(Search Internally & Externally Elimination)

Function	The jug cleaning machine can be adjusted based on the employee.	The jug cleaning machine has a safe design and placed in safe distance.	The jug cleaning machine can provide comfort to the employee who seat on the chair	The jug cleaning machine efficiently cleans on the moss and dirt inside the jug.	The jug cleaning machine efficiently have a bin.
Option 1	Manual Brush Hanger	Rounded Corner	Monobloc Chair	Manual Brush (Without Rotator)	Separated Bin
Option 2	Automatic Brush Hanger	Non-rounded corner	Swivel Chair	Manual Brush (With Rotator)	Merger Bin
Option 3			Adjusted Barstool Chair	Adjusted Automatic Brush	
Option 4			Dining Chair		
Option 5					

TABLE 11
(Search Internally & Externally Consideration Table)

CONSIDERATION TABLE		
No.	Options	Cause
1.	Manual Brush Hanger	There is no major difference in employing for a manual brush hanger to be available and there is not significant effect to the adjusting based on the employee.
2.	Non-rounded corner	The workers want a safety product for themselves, but the product's non-rounded corners mean that there is a danger that the workers will be injured by the sides.
3.	Monobloc Chair	The monobloc chair, made of lightweight stackable polypropylene, is the most prevalent type of plastic chair. The workers want an ergonomic chair to sit on while cleaning the jugs. There would be no difference with the initial chair.
4.	Dining Chair	Dining chairs are frequently used as chairs for dining sets. It is far from the necessities and difficult to move.

c. Concept Combination

TABLE 12
(Search Internally & Externally Result)

	The jug cleaning machine can be adjusted based on the employee.	The jug cleaning machine has a safe design and placed in safe distance.	The jug cleaning machine can provide comfort to the employee who seat on the chair	The jug cleaning machine efficiently cleans on the moss and dirt inside the jug.	The jug cleaning machine efficiently have a bin.
Concept A	Automatic Brush Hanger	Rounded Corner	Swivel Chair	Manual Brush (With Rotator)	Merger Bin
Concept B	Automatic Brush Hanger	Rounded Corner	Swivel Chair	Adjusted Automatic Brush	Merger Bin
Concept C	Automatic Brush Hanger	Rounded Corner	Adjusted Barstool Chair	Manual Brush (With Rotator)	Merger Bin
Concept D	Automatic Brush Hanger	Rounded Corner	Adjusted Barstool Chair	Adjusted Automatic Brush	Merger Bin

After the options has been put, the options were pick one based on the need statements:

TABLE 13
(Search Internally & Externally - Concept A)

	Function				
Concept A	The jug cleaning machine can be adjusted based on the employee.	The jug cleaning machine has a safe design and placed in safe distance.	The jug cleaning machine can provide comfort to the employee who seat on the chair	The jug cleaning machine efficiently cleans on the moss and dirt inside the jug.	The jug cleaning machine efficiently have a bin.
Option 1	Automatic Brush Hanger	Rounded Corner	Swivel Chair	Manual Brush (With Rotator)	Merger Bin
Option 2			Adjusted Barstool Chair	Adjusted Automatic Brush	

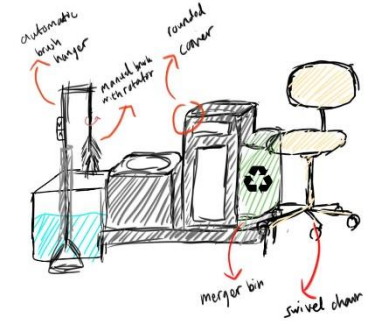

FIGURE 6
(Concept A Sketch)

Pictures above are for the picking and sketch for Concept A, which is picking automatic brush hanger, rounded corner, swivel chair, manual brush with rotator, and merger bin.

TABLE 14
(Search Internally & Externally - Concept B)

	Function				
Concept B	The jug cleaning machine can be adjusted based on the employee.	The jug cleaning machine has a safe design and placed in safe distance.	The jug cleaning machine can provide comfort to the employee who seat on the chair	The jug cleaning machine efficiently cleans on the moss and dirt inside the jug.	The jug cleaning machine efficiently have a bin.
Option 1	Automatic Brush Hanger	Rounded Corner	Swivel Chair	Manual Brush (With Rotator)	Merger Bin
Option 2			Adjusted Barstool Chair	Adjusted Automatic Brush	

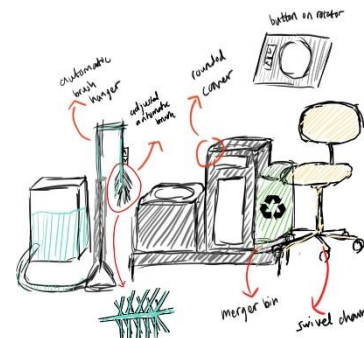

FIGURE 7
(Concept B Sketch)

Pictures above are for the picking and sketch for Concept B, which is picking automatic brush hanger, rounded corner, swivel chair, adjusted automatic brush, and merger bin.

TABLE 15
(Search Internally & Externally - Concept C)

Concept C	Function				
	The jug cleaning machine can be adjusted based on the employee.	The jug cleaning machine has a safe design and placed in safe distance.	The jug cleaning machine can provide comfort to the employee who seat on the chair.	The jug cleaning machine efficiently cleans on the moss and dirt inside the jug.	The jug cleaning machine efficiently have a bin.
Option 1	Automatic Brush Hanger	Rounded Corner	Swivel Chair	Manual Brush (With Rotator)	Merger Bin
Option 2			Adjusted Barstool Chair	Adjusted Automatic Brush	

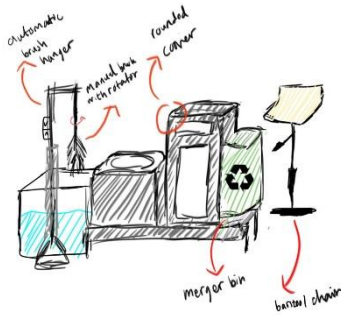

FIGURE 7
(Concept C Sketch)

Pictures above are for the picking and sketch for Concept C, which is picking the automatic brush hanger, rounded corner, adjusted barstool chair, manual brush with rotator, and merger bin.

TABLE 16
(Search Internally & Externally - Concept D)

Concept D	Function				
	The jug cleaning machine can be adjusted based on the employees.	The jug cleaning machine has a safe design and placed in safe distance.	The jug cleaning machine can provide comfort to the employee who seat on the chair.	The jug cleaning machine efficiently cleans on the moss and dirt inside the jug.	The jug cleaning machine efficiently have a bin.
Option 1	Automatic Brush Hanger	Rounded Corner	Swivel Chair	Manual Brush (With Rotator)	Merger Bin
Option 2			Adjusted Barstool Chair	Adjusted Automatic Brush	

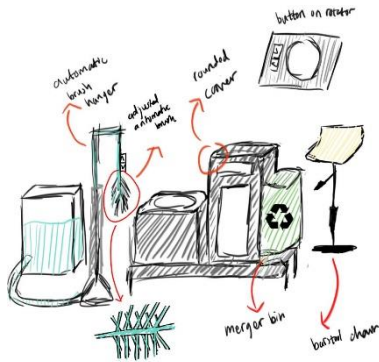

FIGURE 8
(Concept D Sketch)

Pictures above are for the picking and sketch for Concept D, which is picking the automatic brush hanger, rounded corner, adjusted barstool chair, adjusted automatic brush, and merger bin.

d. Concept Selection

After each concepts have their own parts, the concept-screening matrix can be proceeded. It is rated the concepts against the reference using reference as the 'zero' criterion

with comparing the concepts by + for 'better than', 0 for 'same as,', and - for 'worse than' for further consideration. In general, it is best to score each concept on a single criterion before going on to the next; but, when there are a lot of concepts, it is quicker to use the opposite strategy and rate every concept in its entirety before going on to the next.

TABLE 17
(Concept-Screening Matrix)

Selection Criteria	Concepts				Reference
	A	B	C	D	
Ease of handling	0	+	+	+	0
Ease of use	+	0	+	+	0
Reliability of settings	-	0	0	0	0
Dose metering accuracy	0	0	0	0	0
Durability	0	0	0	0	0
Ease of manufacture	-	0	-	-	0
Portability	0	-	0	+	0
Ergonomic	+	+	+	+	0
Production cost	-	-	-	-	0
Safety manufacture	-	0	+	+	0
Sum +s	2	2	4	5	
Sum 0's	4	6	4	3	
Sum -s	4	2	2	2	
Net Score	-2	0	2	3	
Rank	4	3	2	1	
Continue?	Combine	Combine	Yes	Yes	

As can be seen from the above result, the A and B concepts are being merged in order to move on to the next level, while the C and D concepts can be continued based on the ranking of the net score.

TABLE 18
(Concept-Scoring Weighted Percentage)

No.	Selection Criteria	Importance to Customer	Percentage
1	Ease of handling	3,33	9%
2	Ease of use	3,83	11%
3	Additional features	3,50	10%
4	Durability	4,00	11%
5	Modernity	3,17	9%
6	Portability	3,33	9%
7	Safety	4,00	11%
8	Ergonomic	3,50	10%
9	Production cost		10%
10	Safety manufacture		10%
Total		28,67	100%

The table above shows that the importance of the customer from the previous section is utilized to calculate the percentage weighted of each selection criteria. As concept-scoring employs a rating based on references, the table below displays the rating of each number:

TABLE 19
(Concept-Scoring Rating)

Relative Performance	Rating
Much worse than reference	1
Worse than reference	2
Same as reference	3
Better than reference	4
Much better than reference	5

TABLE 20
(Concept-Scoring Matrix)

CONCEPTS							
		A&B		C		D	
Selection Criteria	Weight	Rating	Weight Score	Rating	Weight Score	Rating	Weight Score
Ease of handling	9%	3	0.27	4	0.37	4	0.37
Size of line	13%	3	0.39	4	0.52	3	0.39
Additional features	10%	4	0.40	4	0.40	3	0.30
Flexibility	12%	3	0.36	4	0.48	4	0.48
Modularity	9%	4	0.36	4	0.36	3	0.27
Portability	8%	3	0.24	3	0.24	4	0.32
Customization	11%	3	0.33	4	0.44	4	0.44
Ergonomics	10%	3	0.30	4	0.40	4	0.40
Production cost	10%	4	0.40	3	0.30	4	0.40
Safety maintenance	10%	3	0.30	4	0.40	3	0.30
Total Score			3.23		3.55		3.95
Rank			1		2		3
Concept			No.		No.		Number

Based on the table above, the combined A&B concept has a total score of 3.23, the C concept has a total score of 3.55, and the D concept has a total score of 3.95 according to the concept-scoring system. The D concept, which is now being developed, has the greatest ranking and the highest score. After it being calculated, the final design finished by the picture below:

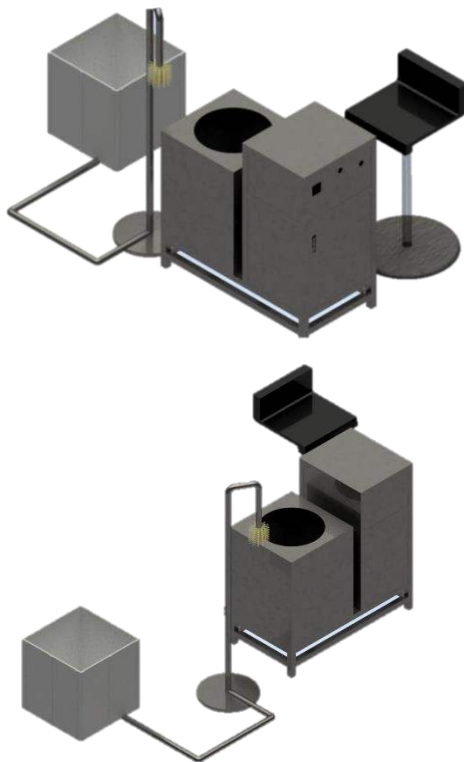

The final machine has an additional part that come from Concept D, with the change of the chair. The place where it places the water on the jug is now being automatically given from the pipe to the brush which also automatically turn for cleaning on the jug inside.

V. CONCLUSION

Workers in the pre-treatment area utilize the jug cleaning equipment to clean the jug before it enters the main processing line. The product is designed using the workers' questionnaires, interviews, and observations that was spread. The device has been successfully improved to provide workers with comfort when working 5-6 hours straight per shift and to allow them to work more efficiently. Even if the product has an unfinished statement, and the electricity supply is still close to the machine, it has little effect on the workers. In this after improvement, the workers may now work more

efficiently than before thanks to the improved and added elements.

REFERENCES

- [1] Bridger, R. S. (2018). Introduction to Human Factors and Ergonomics, 4th Edition. Boca Raton, FL, USA. CRC Press
- [2] Chang, C.-C., & Wu, J.-C. (2009). The underlying factors dominating categorical perception of product form of mobile phones. International Journal of Industrial Ergonomics, 39(5), 667–680. doi:10.1016/j.ergon.2009.02.012
- [3] Chuan, T.K., Hartono, M., Kumar, N. (2010). Anthropometry of the Singaporean and Indonesian populations. Int. J. Ind. Ergon. 40, 757-766.
- [4] Harotono, M. (2018). Indonesian anthropometry update for special population incorporation Drillis and Contini revisited. International Journal of Industrial Ergonomics. 64, 89-101.
- [5] Kishita, Y., Mizuno, Y., Fukushige, S., & Umeda, Y. (2020). Scenario structuring methodology for computer-aided scenario design: An application to envisioning sustainable futures. Technological Forecasting and Social Change, 160, 120207. doi:10.1016/j.techfore.2020.120207.
- [7] Kromer, K.H.E., Drandjean, E. (1997). Fitting the Task to the Human: a Textbook of Occupational Ergonomics, fifth ed. CRC Press.
- [8] Liang, Y., et. al. (2021). The Core Values and Methodology of Cross-Cultural I-Sustainability Design Thinking. 13th International Conference. 122, 12771.
- [9] Liu, Z., et. Al (2021). The Influence of Gender on Human's Cognitive Ability and the Correlation Research of Different Cognitive Dimensions. 32rd HCI International Conference, HCII 2021.
- [10] Luo, S.-J., Fu, Y.-T., Zhou, Y.-X. (2012). Perceptual matching of shape design style between wheel hub and car type. Int. J. Ind. Ergon. 42 (1), 90–102.
- [11] McDonough, W & Braungart, M. (2002). Cradle to Cradel: Remaking the Way We Make Things. North Point Press, 236.
- [12] Salmon, P. M., Read, G. J. M., Walker, G. H., Stevens, N. J., Hulme, A., McLean, S., & Stanton, N. A. (2020). Methodological issues in systems Human Factors and Ergonomics: Perspectives on the research–practice gap, reliability and validity, and prediction. Human Factors and Ergonomics in Manufacturing & Service Industries. doi:10.1002/hfm.20873
- [13] Simatupang, Togar. (1995). Permodelan Sistem. Klaten: Nindita.
- [14] Teixeira, R.C.M., Guimarães, W.P.S., Ribeiro, J.G., Fernandes, R.A., Nascimento, L.B.F., Torné, I.G., Cardoso, F.S., Monteiro, G.R. (2022). Analysis of the Reduction of Ergonomic Risks through the Implementation of an Automatic Tape Packaging Machine. International Journal of Environmental Research and Public Health, 19 (22), art. no. 15193.
- [13] Ulrich, K.T. (2020). Product Design and Development Seventh Edition. New York: McGraw-Hill Education.

- [14] Wang, W. M., Li, Z., Liu, L., Tian, Z. G., & Tsui, E. (2018). Mining of affective responses and affective intentions of products from unstructured text. *Journal of Engineering Design*, 29(7), 404–429. doi:10.1080/09544828.2018.144805.
- [15] Wei, T., Wang, W., Yu, S. (2022). Analysis of the Cognitive Load of Employees Working from Home and the Construction of the Telecommuting Experience Balance Model. *Sustainability* 2022, 14, 11722. doi.org/10.3390/su141811722
- [16] Zoaktafi, M., Zakerian, S. A., Choobineh, A., Nematollahi, S., & Kazemi, R. (2020). Relationship between mental workload and salivary cortisol levels: A field study. *Work*, 1–6. doi:10.3233/wor-203287