

DESIGN OF EXPERIMENTS APPLICATION USING TAGUCHI APPROACH TO IDENTIFY WOVEN FABRICS DEFECTS BY IMAGE PROCESSING AT CV. MAEMUNAH MAJALAYA

Ditha Yusfiana Maryani¹, Haris Rachmat², Denny Sukma Eka Atmaja³

^{1,2,3}Industrial Engineering Study Program, Industrial Engineering Faculty, Telkom University

¹ditha.maryani33@gmail.com, ²haris.bdg23@gmail.com, ³dennysukma@gmail.com

Abstract

Grey fabric is one of the woven fabrics types that become the core product in CV. MAEMUNAH MAJALAYA. The inspection activity in this company is still conducted manually by using human vision. Therefore, that existing condition gives a very crucial implication in production flow. The limited numbers of inspection station cannot afford the production volume that increases in every week. Each station is only capable to inspect 30 meters of fabrics in one hour, while there are more than 20.000 meters of fabrics demand in every week. Therefore, automated system through image processing system for conducting the inspection activity can be implemented to optimize the productivity.

In order to support the image processing system, this study will conduct design of experiment (DOE) using Taguchi approach to get the required data or information to build the image processing application. The Taguchi approach is utilized different combinations of factors and levels. The chosen factors are 463 lux light intensity, 20 cm camera distance, 8 MP camera resolution, 0.2 threshold, and 47 grayscale with low, medium, and high as the levels for each factors. Therefore, through Taguchi Orthogonal Array there will be 27 of experiments combinations will be discussed in this study

Keywords: Design of Experiment, Taguchi Approach, Image Processing System, Woven Fabrics, Fabrics Inspection, Orthogonal Arrays.

1. Introduction

CV. MAEMUNAH MAJALAYA is one of the textile industries which focus on woven fabrics production. The manufacturer is located in Majalaya, Kabupaten Bandung. A quality control process is very crucial in this company, because the standardized quality of woven fabrics should be delivered to the customers. Then, the woven fabrics defects must be avoided as minimum as possible. In order to reduce the defective product, inspection or rework should be implemented. inspection carried out to check and separate the defective product from non-defective products. Though, the inspection is already conducted in this company, there are still remaining defects. Regarding of Table 1, the woven fabrics defects is classified into three highest defects rank which are *Amrol*, *Rabuk*, and *Kanjian*, while this study is only focused on *Amrol* and *Robuk*. Both of those defects have 16,98% and 15,30% of fabrics defects percentage within January 2015. According to SNI-08-0277-1989 *Amrol* and *Rabuk* are known as broken yarn and unwoven yarn defects.

Table 1. Total Woven Fabrics Defect Rank in January 2015 of CV. MAEMUNAH MAJALAYA

No	Fabric Defect Rank	Total Fabrics Defects	% Fabrics Defects
1	<i>Amrol</i>	1445	16,98
2	<i>Rabuk</i>	1302	15,30
3	<i>Kanjian / Meter Kurang</i>	976	11,47

The main issue in CV. MAEMUNAH MAJALAYA is the inspection process that still conducted manually by using human vision. Four inspection process with two operators in each stations need a very long time to check or inspect the finished product. Furthermore, each station is only capable to inspect 30 meters of fabrics in one hour, while there are more than 20.000 meters of fabrics that should be inspected every week. The Figure 1 indicates that the production of woven fabrics has an increases in every week with more than 20.000 meters of grey fabrics demand that should be fulfilled in each week. It also indicates that the production volume is mostly increasing every week but it is not along with the inspection volume that have constant capacity.

Therefore, based on Figure 1, the inspection capacity cannot fulfill the production volume in every week which cause massive bottle neck. The unbalance inspection volume with production volume is shown in Figure 1 which have become the crucial issue for this company because the massive bottle neck is absolutely cause the delayed product distribution to the customers. The more increasing of production volume, then the larger the bottle neck will be. Moreover, automated system through image processing system for conducting the inspection activity can be implemented to optimize the company productivity.

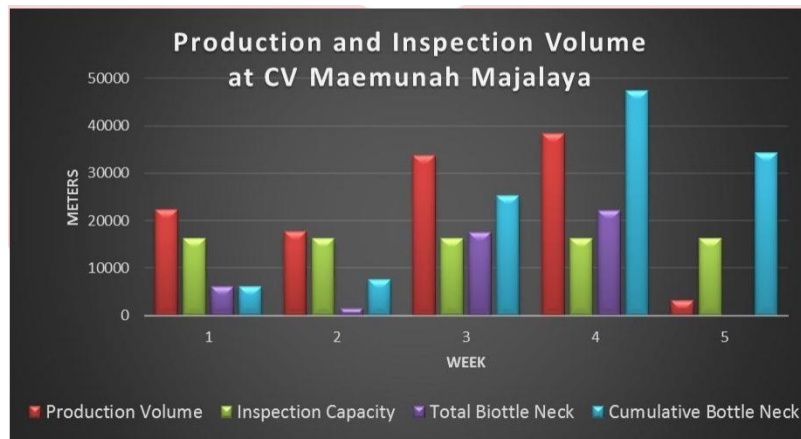

Figure 2. Production Volume and Inspected Fabrics in January 2015 at CV Maemunah Majalaya

Based on the previous study conducted by Atiquel Islam et al. (2008) on his journal about Automated Textile Defect Recognition System Using Computer Vision and Artificial Neural Networks stated that the inspection speed could be improved until 300% of increases from manual vision become automated system, as well as the 10% increases for defect detection rate [1]. It is shown in the Table 2 that automated system could give improvement and optimize the inspection process for textile defect recognition.

Table 2. Visual Inspection Versus Automated Inspection

Inspection Type	Visual	Automated
Fabrics types	100 %	70 %
Defect detection rate	70 %	80 %
Reproducibility	50 %	90 %
Objective defect judgment	50 %	100 %
Statistics ability	0 %	95 %
Inspection speed	30 meters / minutes	120 meters / minutes

Before implementing the automated system by using image processing for supporting the inspection activity, this study will conduct design of experiment (DOE) in order to get required data or information to build the image processing application. This method utilized different combinations and levels of factors with their parameters through orthogonal arrays which have been created to design experiments that are smaller in number but produce more reproducible performance than the factorial design [2]. Thus, there will be $35 = 243$ of experiment combinations which require more time and process, but in Taguchi there will only 27 of experiment combinations in order to get optimum DOE result.

2. Plan of Experiment

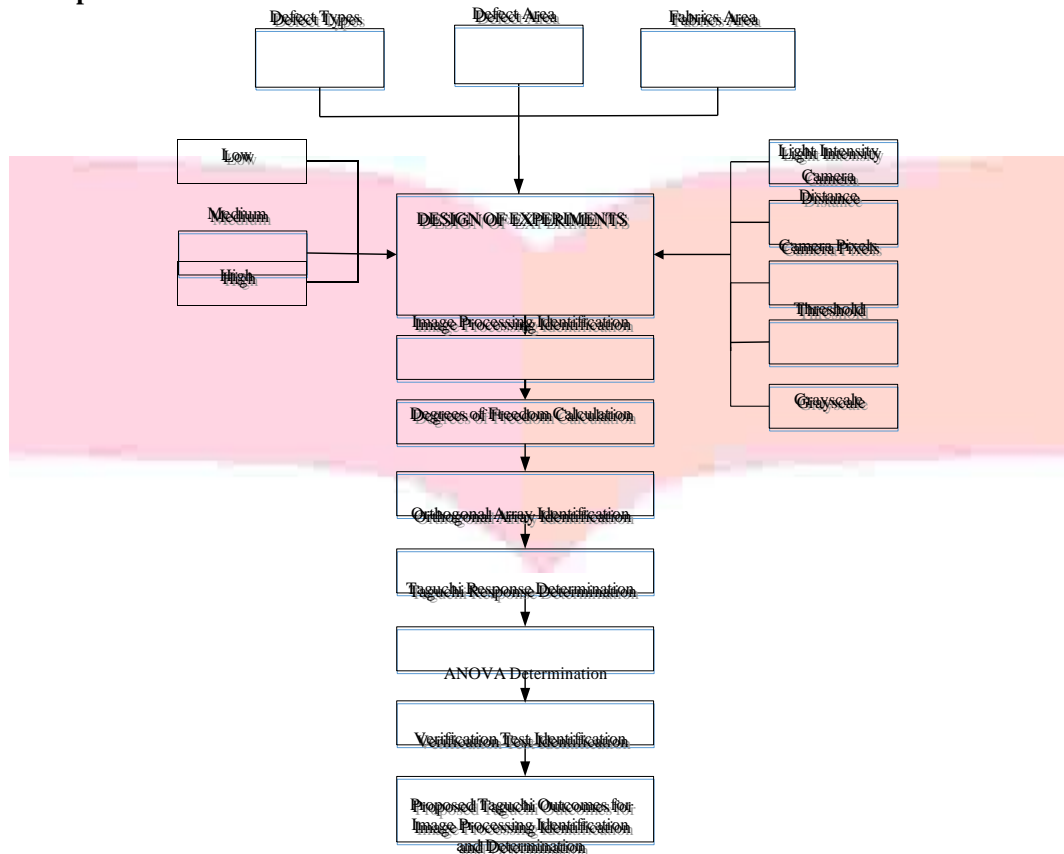

Figure 3 Conceptual Model of Research

The conceptual model is represented in Figure 3 which describes the input for the experiments are defects types, defects area, and fabrics area. The initial stage is started from the design of experiments stage that consist of low, medium, and high levels as well as the five factors, light intensity, camera distance, camera pixels, threshold, and grayscale. Therefore, the next stage is image processing identification. After determining the Taguchi responses, then the statistical stage should be conducted which consist of ANOVA determination and verification test identification, then the output for this research is proposed the Taguchi outcomes for image processing identification and determination.

2.1 Image Processing

According to Kadir and Susanto (2013), image processing is a common term for various methods or techniques that exist in order to manipulate and modify the image in various ways. Image processing is a crucial part for the various applications, such as pattern recognition, remote sensing by satellite or aircrafts, and machine vision [3]. On pattern recognition, the image processing is processed to separate objects from the background automatically. Furthermore, the object will be processed by the classifier pattern. In this study, the image processing system will be implemented for identifying the woven fabrics defects which consist of broken yarn and unwoven yarn defects. Through this system, the woven fabrics defects can be recognized and detected automatically. Moreover, the previous study with the objective to identify products based on its quality has been developed. Atmaja (2015), implement the image processing system to identify the quality of ceramics surface.

2.2 Design of Experiments Using Taguchi Approach

Basically there are three kind of DOE methods to determine the required information for optimizing the textile inspection process. Those are factorial design, Taguchi method, trial and error, as well as response surface. However, there are still issues that occur in manufacture industries when they try to implement the DOE method. Trial and error method are still popular DOE in several manufacturers, but this is a very complex and not easy use especially for large number of experiments has to be carried out when the process parameters numbers is increasing (Nalbant et al, 2007). The complexity of trial and error method can cause the high of manufacturing cost and also it takes more time to conduct the process of development. Therefore, the Taguchi method for making the design of experiment can be the proper option for improving the inspection process along with maintain the product

quality. Taguchi method is designed to decrease the experimental time of engineering as well as reduce the operational cost. Besides that, this method will give less effort for product improvement and brings the simplicity for continuous improvement. This study will implement the Taguchi method in order to get simplicity in data collection, efficient practical in designing the image processing application, as well as received process parameters that can make DOE is possible in any business operation.

Taguchi method is a brand new methodology in the field of engineering that aims to make improvement to the quality of products and processes as well as can reduce the cost and resources as minimum as possible (Taguchi, 2001). The target of this method is to make the product is not sensitive toward noise, this it can be defined as robust design. Robust design is one of engineering methodology for optimizing the product and process conditions which minimally sensitive to the several variation causes and which produce very high quality of product with low development and manufacturing cost (Phadke, 2008).

2.3 Analysis of Variances (ANOVA)

According to the research of improving the design of parallel applications using statistical methods by C.M. Amarandei et al (2011) defines that the parallel performance of application is often evaluated against factors such as speedup, efficiency, scalability which assume measurements of processing time, communication time, and idle time [4]. By using statistical analysis of experimental data through way analysis of variance (ANOVA) techniques. ANOVA is capable to identify the main effects and interaction of factors such as performance metrics. ANOVA or analysis of variance table for response variable is very useful tool for identifying main and interaction effects of several factors that are significant in statistics way. Analysis of variance is capable to expand the similarity testing from the average of two values and become similar average of multiple values in simultaneously (Wibisono, 2005).

3. Discussion

3.1 Existing of Experimental Situations

According to the observation data in CV. MAEMUNAH MAJALAYA, it can be obtained the camera distance and light intensity for the existing inspection station. Thus this data will become the reference to determine the factors and levels for Taguchi Experiment. The range of light intensity of existing condition is 203-210 Lux while the existing distance is 70 cm. The width of inspected fabrics is 74 cm and the length is 96,52 cm. Besides that, the camera that is implemented for this research is webcam Logitech C525. The sample size of woven fabrics that will be used for this experiment is 16 cm x 13 cm.

3.2 Design of RIG

The RIG framework in this research is used in the process of image acquisition. The visual framework is made from iron and its size is 50 x 33 x 73,32 cm. This framework is used to put the webcam that used for the shooting process and set the webcam distance, and also the rig is used to put the light source of the 45-Watt fluorescent light.

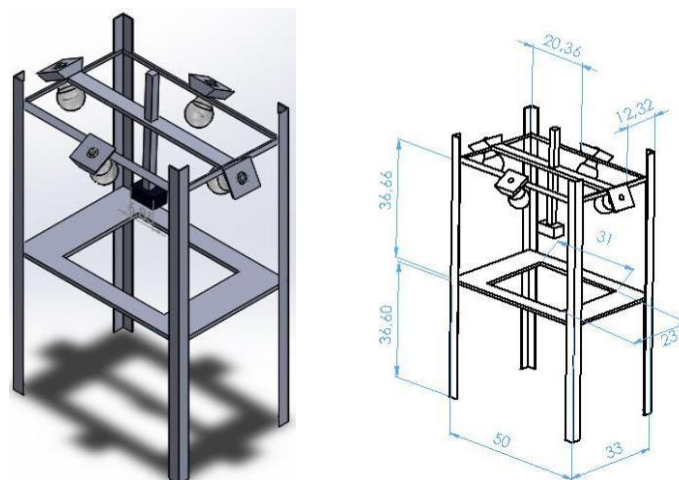

Figure 4 Design of RIG in Isometric and Dimension View

3.3 Determination of Factors and Levels

The collecting and data processing for identifying woven fabrics defects through image processing consist of the determination of camera resolution, the camera distance, the light intensity, edge threshold, and grayscale variables. According to previous study conducted by Atmaja (2015) stated that the light intensity and camera are considered to be the factors for influencing the image quality in image processing. Then, for this study there are several additional factors that included in order to obtain accurate and detailed result for image quality [5].

Those variables are combined in order to captured the image and processed them into image processing program on Matlab. Then, the error range will be analyzed to gain the differences between the image in pixels and centimeters. The error range will become the input for Design of Experiment through Taguchi method. The statistical analysis is conducted to obtain the validated data, those analyses are Normality test, analysis of variance, as well as Tukey test. Table 3 indicates the used factors and variables for experimental design through Taguchi approach. The 203 lx of light Intensity is determined as the low level for the experiment. This 203 lx is obtained from four fluorescent lamps that installed on each sides of the Rig with the height of each lamps are 36,66 cm. Similar with the low level of light intensity the 463 lx is obtained by doubling the low level. The last light intensity which is 863 lx obtained as the maximum intensity from four fluorescent lamps.

Table 3. The Factors and Levels for Design of Experiments

Factors	Levels		
	Low	Medium	High
Light Intensity	203 lx	463 lx	863 lx
Camera Distance	17 cm	20 cm	22 cm
Camera Resolution	VGA	2 MP	8 MP
Threshold	0,1	0,2	0,3
Grayscale	30	35	47

Based on Table 3, The 17 cm of camera distance is chosen as low level because its the minimum range for the camera to capture the image followed by the area of the fabrics. The 22 cm for high level is decided because is the maximum capacity to recognize the defect, when the camera distance is more than 22 cm then the fabrics defect will not be detected. The levels for camera resolution is obtained from the device specification for its resolution. In this study the low level of camera resolution is VGA which has become the lowest resolution in Logitech C525. The next level is medium level which has 2 MP of camera resolution, it is obtained from the second resolution capability of Logitech C525. The last level is 8 MP for high parameter, this resolution is gained from the maximum resolution capability of Logitech C525. Furthermore, The grayscale levels are chosen from range 30 – 50. This is caused by the proper image quality is obtained from those ranges. When the grayscale value is below 30 the noises on image surface will increase and affect the quality of the image. The determination of threshold depends to the threshold value itself. The smaller the value then the more detail the image for detecting the defects, thus increases of noises will appear on the image surface. This experiments will choose 0,1 as the low level. 0,2 as the medium level, and 0,3 as the high level.

3.3.1 Algorithm Design for Unwoven and Broken Yarn Identification

1. Converting the image from RGB (Red, Green, Blue) into Grayscale image.
2. Converting the image from grayscale into binary image

The similar process with the previous step is conducted to convert the image from grayscale into binary. However, the average colours difference will be grouped into two, if the intensity of color starts from 0 up to 255 then the retrieved middle value is 128, but when it is below 128 then the colors will tend to be black and when above 128 the color will tend to be white.

3. Edge Detection

The internal characteristics of the edge-dividing area are similar, while the differences can be found in the areas. The main function of edge detection is to extract the characteristics of discrete parts by the difference in the image characteristics of the object, and then to determine the image area based on the closed edge. The edge detection method for this study is edge detection based on the optimum operator which known as Sobel edge detection.

4. Filling Operation
5. Area measurement of woven fabric and its defect

6. Calculation of area measurement deviation

The result from area measurement deviation is used for verification value. the area of fabric both in cm and pixels will be compared with the defects area for both unit. Then, those comparison result is become the measurement error value by using the absolute reduction operation.

$$\text{Deviation} = \text{abs} \left(\frac{F1}{F2} - \frac{F1'}{F2'} \right) \quad (1)$$

F1 : The fabric area (cm) F2

: The defect area (cm) F1' :

The fabric area (pixels) F2' :

The defect area (pixels)

3.4 Taguchi Approach

In this study, the design of experiments by using Taguchi approach is implemented which scientifically select the most appropriate option when the experiments are confronted with many possibilities. This Taguchi approach will be calculated by using statistical software, Minitab 16. The next step of this research is to determine the factors and levels for determining the size of Taguchi's experiments. Thus, the researcher needs the existing data from the company to measure each level and factor. There will be five factors and three levels which is in Taguchi approach only a small fraction of all possible conditions need to be tested, then "13 three-level factors" of orthogonal array will be used as the experimental situation. Based on the number of factors and levels, the chosen matrix for orthogonal array is L₂₇(3¹³) with 27 combinations.

Table 4. Orthogonal Arrays of L₂₇(3¹³) Combinations



No	Light Intensity	Camera Distance	Camera Resolution	Threshold	Grayscale
1	203 lx	17 cm	VGA	0.1	30
2	203 lx	17 cm	VGA	0.1	35
3	203 lx	17 cm	VGA	0.1	47
4	203 lx	20 cm	2MP	0.2	30
5	203 lx	20 cm	2MP	0.2	35
6	203 lx	20 cm	2MP	0.2	47
7	203 lx	22 cm	8MP	0.3	30
8	203 lx	22 cm	8MP	0.3	35
9	203 lx	22 cm	8MP	0.3	47
10	463 lx	17 cm	2MP	0.3	30
11	463 lx	17 cm	2MP	0.3	35
12	463 lx	17 cm	2MP	0.3	47
13	463 lx	20 cm	8MP	0.1	30
14	463 lx	20 cm	8MP	0.1	35
15	463 lx	20 cm	8MP	0.1	47
16	463 lx	22 cm	VGA	0.2	30
17	463 lx	22 cm	VGA	0.2	35
18	463 lx	22 cm	VGA	0.2	47
19	863 lx	17 cm	8MP	0.2	30
20	863 lx	17 cm	8MP	0.2	35
21	863 lx	17 cm	8MP	0.2	47
22	863 lx	20 cm	VGA	0.3	30
23	863 lx	20 cm	VGA	0.3	35
24	863 lx	20 cm	VGA	0.3	47
25	863 lx	22 cm	2MP	0.1	30
26	863 lx	22 cm	2MP	0.1	35
27	863 lx	22 cm	2MP	0.1	47

3.5 Image Processing

The influence factors and levels will be shown in this image processing stage. Those factors and levels is going to be selected through Orthogonal arrays matrix in order to gain the proper detection for broken yarn and unwoven yarn defects. One of the results for defect detection of unwoven yarn and broken yarn are listed below:

Experiment 1
 Light Intensity : 203 lx
 Camera Distance : 17 cm
 Camera Resolution : VGA
 Threshold : 0,1
 Gray Scale : 30

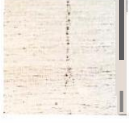
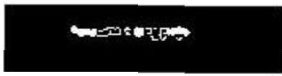
Table 5. Experiment 1 Image Processing Result

	Unwoven Yarn	Broken Yarn
RGB Image		
Detected Defect		

3.6 Experimental Result Analysis

3.6.1 Error Rate Analysis for Defect Measurement

The analysis for this study is more emphasis on the level of accuracy by comparing the level of error that is generated based on the reference data obtained from SNI 08-0277-1989. Table 6 shows the summary of the results from error rate calculation of unwoven yarn defect by comparing the area of the fabrics with the binary image. Regarding of the 12th experiment shows the combination from 463 lx of light intensity, 20 cm of camera distance, 2 MP of camera resolution, 0,3 of threshold, and 47 of grayscale, that combination generate the highest error rate value which caused by the high value of threshold and grayscale, thus the defect spot on the binary image is faded.

Table 6. Unwoven Yarn Defect Error Rate

Experiment No	Unwoven Yarn Defect				
	Fabric Area (px)	Defect Area (px)	Fabric Area (cm)	Defect Area (cm)	Error
1	265360	624	208	0,495	1,20%
2	265360	584	208	0,495	8,13%
3	265360	584	208	0,495	8,13%
4	317346	1197	208	0,495	36,91%
5	317346	1197	208	0,495	36,91%
6	317346	1056	208	0,495	28,48%
7	4981844	10121	208	0,495	17,14%
8	4981844	9268	208	0,495	27,92%
9	4981844	8910	208	0,495	33,06%
10	1817654	3417	208	0,495	26,59%
11	1817654	2865	208	0,495	50,98%
12	1817654	2660	208	0,495	62,62%
13	6634116	13032	208	0,495	21,15%
14	6634116	12495	208	0,495	26,35%
15	6634116	12495	208	0,495	26,35%
16	176656	325	208	0,495	29,36%
17	176656	310	208	0,495	35,62%
18	175192	310	208	0,495	34,49%
19	7184100	14652	208	0,495	16,69%

20	7184100	13930	208	0,495	22,73%
21	7184100	12059	208	0,495	41,78%
22	203318	504	208	0,495	4,00%
23	203318	476	208	0,495	1,65%
24	203318	342	208	0,495	41,48%
25	671414	2254	208	0,495	29,11%
26	671414	1595	208	0,495	0,18%
27	671414	1305	208	0,495	22,44%

The Table V.7 shows that the highest percentage of the error rate measurement for broken yarn defect is obtained at the 23rd experiments which is 25,23 % and consist of 863 lx of light intensity, 20 cm of camera distance, VGA of camera resolution, 0,3 of threshold value, and 35 of grayscale value

Table 7. Broken Yarn Defect Error Rate

Experiment No	Broken Yarn Defect				
	Fabric Length (px)	Defect Length (px)	Fabric Length (cm)	Defect Length (cm)	Error
1	621	169	16	5	14,83%
2	621	172	16	5	12,83%
3	621	169	16	5	14,83%
4	1397	386	16	5	13,10%
5	1397	375	16	5	16,42%
6	1397	375	16	5	16,42%
7	2570	827	16	5	2,89%
8	2570	818	16	5	1,82%
9	2570	812	16	5	1,09%
10	1521	429	16	5	10,80%
11	1521	417	16	5	13,98%
12	1521	417	16	5	13,98%
13	2865	819	16	5	9,32%
14	2865	819	16	5	9,32%
15	2865	819	16	5	9,32%
16	490	144	16	5	6,34%
17	490	140	16	5	9,37%
18	490	159	16	5	3,69%
19	3137	896	16	5	9,41%
20	3137	882	16	5	11,15%
21	3137	868	16	5	12,94%
22	553	156	16	5	10,78%
23	553	138	16	5	25,23%
24	553	138	16	5	25,23%
25	1277	406	16	5	1,71%
26	1277	405	16	5	1,47%
27	1277	404	16	5	1,22%

3.6.2 Signal to Noise (S/N) Ratio Analysis

S/N Ratio is used to select the appropriate factors or parameters which contribute to the reduction of response variance. Besides that, S/N ratio is also implemented to minimize the error variance which is variance that caused by factors. In Taguchi approach, ANOVA is used to estimate the S/N ratio in order to identify the control parameter settings that will result in a solid performance (robust), so it can also determine the optimal conditions (Nur Firstiawan, 2012). The suitable quality characteristics to identify the woven fabrics defect is “smaller is better”, because the smaller the error rate, then the better the response result will be. Smaller magnitude of the results is always preferred over the others and the theoretical target is zero. The practical value of the lowest achievable can be set to some appropriate numbers (Ranjit K. Roy, 2001:31).

$$S/N = -10 \text{Log}_{10} \left(\frac{\sigma_1^2 + \sigma_2^2 + \sigma_3^2 + \dots + \sigma_n^2}{n} \right) \tag{2}$$

The signal to noise ratio result is obtained from the Taguchi calculation through statistical software, Minitab 17. The Table V.4 is indicated the summary of result from signal to noise ratio result. In order to obtain the optimum settings such as shown by Table V.8 and Figure 5, the S/N ratio method in this election depends on the quality characteristics. Moreover, "smaller is better" is the chosen quality characteristic measurement which always look at the smallest value. It is highly noticeable that the chosen optimum factors and levels for identifying the unwoven yarn and broken yarn defects are shown in the Table V.8 and Figure 5.

Table 8. Signal to Noise Ratio Results

Level	Light Intensity	Camera Distance	Camera Resolution	Threshold	Grayscale
Low	15,22	14,35	15,64	18,96	16,09
Med	12,28	13,85	14,81	12,73	16,46
High	17,54	16,84	14,59	13,36	12,48

Figure 5. Line Diagram Signal to Noise Ratio Results

3.7 Statistical Analysis

The following data collecting and data processing is already conducted. After that, the next step is to conduct statistical analysis of the obtained data in order to determine the data distribution, fac. After that, the next step is to conduct statistical analysis for the obtained data in order to determine the data distribution, factors, or even independent variables that have a significant influence on the dependent variables.

3.7.1 Normality Test for Error Rate Response

Regarding of Kolmogorov-Smirnov method the obtained hypothesis from distributional is rejected if the test statistic (D) is greater than the critical value obtained from the table as well as if the P-value is less than α (5%) and vice versa. Thus, if the data is normally distributed then the inferential statistic method can be done for making the decision, but if the data is not normally distributed then the nonparametric testing will be conducted. The Figure 6 and 7 indicate the normality test calculation result by using Matlab 16 for both unwoven yarn and broken yarn defect. Moreover, the analysis for those normality test calculation result is also explained.

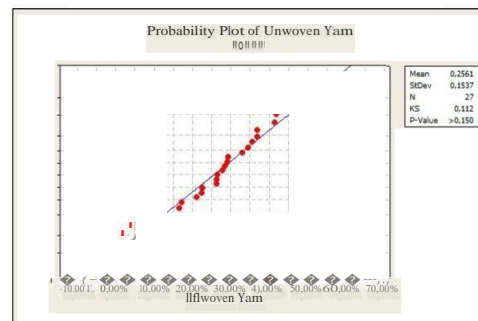

Figure 6. Normality Test of Error Rate Response for Unwoven Yarn Defects

The hypothesis analysis for this result is shown below :

H0 : Unwoven yarn error rate is normally distributed

H1 : Unwoven yarn error rate is not normally distributed

α : 5%

Criteria: Reject H0 if Z-count > Z-table or P-value < α

Regarding of the Kolmogorov-Smirnov result, it can be stated that the data for error rate of unwoven yarn defect is accepting the H0 hypothesis or normally distributed which shows by the P-Value (0,150) is greater than the α (5%). Thus, the statistical test will be conducted by using parametrical method.

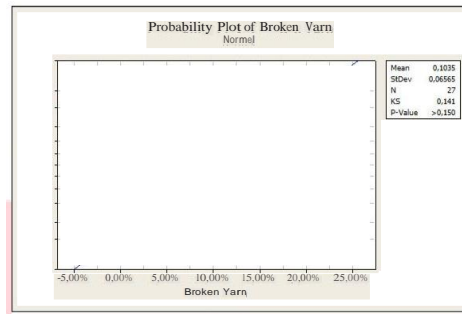

Figure 7. Normality Test of Error Rate Response for Broken Yarn Defects

The hypothesis analysis for this result is shown below :

- H0 : Broken yarn error rate is normally distributed
- H1 : Broken yarn error rate is not normally distributed
- α : 5%

Criteria: Reject H0 if Z-count > Z-table or P-value < α

Regarding of the Kolmogorov-Smirnov result, it can be stated that the data for error rate of broken yarn defect is accepting the H0 hypothesis or normally distributed which shows by the P-Value (0,150) is greater than the α (5%). Thus, the statistical test will be conducted by using parametrical method.

3.7.2 The Analysis of Variance (ANOVA) for Error Rate Response

The analysis of variance or ANOVA is implemented in this study to analyze the effects of the most significant factors in influencing the dependent variables which are the error rate for measuring the fabrics defects, unwoven yarn and broken yarn defects. The calculation for this variance analysis is using the statistical software Minitab 16. There is a specific requirement in order to obtain the accepted or rejected hypothesis. If the P-value from the tested statistic is less than α (5%), it indicates that those response factors are significantly have effect to the experiment. However, if the P-value from the tested statistic is more than α (5%) then the response factors have not any effect to the experiment. Based on the Table 9 the independent variables that have significant effects toward the dependent variables are camera distance and camera resolution which shows by the significance value for each independent factor. The first one is camera distance, its significance is less than α (5%), $0,000 < 0,05$. For the second independent factor which is camera resolution, its significance is also less than α (5%), $0,002 > 0,05$.

Table 9. ANOVA Results of Error Rate Response for Defects Measurements

Source	DF	SS	MS	F	P
Light Intensity	2	0,0009577	0,0004788	0,52	0,604
Camera Distance	2	0,0696204	0,0348102	37,88	0,000
Camera Resolution	2	0,0176204	0,0088102	9,59	0,002
Threshold	2	0,0058610	0,0029305	3,19	0,068
Grayscale	2	0,0033085	0,0016543	1,80	0,197
Error	16	0,0147024	0,0009189		
Total	26				

3.7.3 Tukey's HSD (Honest Significant Difference) Test

If the analysis of variance conclusion is accepting the H0 which means that all tested treatment is giving the same effect, then the post-hoc test is not necessary required. However, the different treatment will be conducted if the obtained conclusion is rejecting H0 which means that there are differences in the effect of tested treatment. Therefore, it is necessary to do post-hoc test in order to know which treatment is giving different effect. One of post-hoc tests that will be used in this study is honestly significant difference test or Tukey test. This study will use 95% or α 0,05 as the confidence interval, by comparing the difference between each average with a P-value. Table V.6 and V.7 show the Tukey Test Results camera distance and camera resolution variables.

Table 10. Tukey Test Result for Camera Distance Variable

Camera Distance = 17 cm subtracted from:				
Camera Distance	Difference of Means	SE of Difference	T-Value	Adjusted P-Value
20 cm	0,02263	0,01429	1,584	0,2808
22 cm	-0,09460	0,01429	-6,620	0,0000
Camera Distance = 20 cm subtracted from:				
Camera Distance	Difference of Means	SE of Difference	T-Value	Adjusted P-Value
22 cm	-0,09460	0,01429	-6,620	0,0000

Based on Table 10, the 17 cm variable for camera distance that subtracted from 22 cm variable has significantly difference because the P-value is less than α , $0,0000 < 0,05$. In addition, the 20 cm camera distance that subtracted from 22 cm camera distance has also significantly difference because the P-value is less than α , $0,0000 < 0,05$. Thus, the camera distance levels which have significant difference is the subtraction of 17 cm and 22 cm as well as the subtraction of 20 cm and 22 cm.

Table 11. Tukey Test Result for Camera Resolution Variable

Camera Resolution = VGA subtracted from:				
Camera Resolution	Difference of Means	SE of Difference	T-Value	Adjusted P-Value
2 MP	-0,03781	0,01429	-2,646	0,0440
8 MP	-0,06208	0,01429	-4,345	0,0014
Camera Resolution = 2 MP subtracted from:				
Camera Resolution	Difference of Means	SE of Difference	T-Value	Adjusted P-Value
8 MP	-0,02427	0,01429	-1,699	0,2361

Based on Table V.7, the VGA variable for camera resolution that subtracted from 8 MP variable has significantly difference because the P-value is less than α , $0,0014 < 0,05$. Thus, the camera resolution level which has significant difference is the subtraction of VGA and 8 MP variables.

4. Conclusions

The design of experiments by using Taguchi approach is conducted in order to obtained the optimum factors and levels for identifying the unwoven yarn and broken yarn defects through image processing. 27 experiments were conducted based on the Taguchi Orthogonal Array because the numbers of factors and level are five and three. The identified defects types are unwoven yarn and broken yarn which was used in this study. Therefore, for the unwoven yarn error percentage was comparing the fabrics area in cm and pixels, while the broken yarn error percentage was comparing the fabrics length in cm and also in pixels. Therefore, the influential factors and levels sequences for both defects error percentage calculation result through S/N Ratio are medium level (46x lx) of light intensity, medium level (20 cm) of camera distance, high level (8 MP) of camera resolution, medium level (0.2) of threshold, and high level (47) of grayscale. The quality measurement for Taguchi analysis was implementing smaller is better measurement, this is caused by the smaller of the error value then the better the results will be. Regarding of the conducted normality test in this study, the error rate response for unwoven yarn and broken yarn defects were normality distributed. The method that used for the normality test is Kolmogorov-Smirnov. Therefore, the analysis of variance is implanted in order to obtain the most significant factors that influence the dependent variables. The independent variables that have significant effects toward the dependent variables are camera distance and camera resolution. The camera distance levels which have significant difference is the subtraction of 17 cm and 22 cm as well as the subtraction of 20 cm and 22 cm. In addition, the camera resolution level which has significant difference is the subtraction of VGA and 8 MP variables.

References

- [1] Islam, Atiquel *et al.* 2008. "Automated Textile Defect Recognition System Using Computer Vision and Artificial Neural Networks", International Journal of Mechanical, Aerospace, Industrial, Mechatronic, and Manufacturing Engineering, Vol. 12, No.1.
- [2] K. Roy, R., 2001. Design of Experiments Using Taguchi Approach. New York: John Wiley & SONS, Inc.

- [3] Kadir, A., & Susanto, 2013. Teori Aplikasi Pengolahan Citra. Yogyakarta: ANDI.
- [4] Amarandei, C.M., Lepadatu, D., & Caraiman, S. 2011. Improving the Design of Parallel Applications using Statistical Methods. Journal of Applied Sciences, Vol. 11: 932-942.
- [5] Sukma Eka Atmaja, D., 2015, Optimization of Measurement Dimension and Surface Defect For Ceramic Tile Using Image Processing and Full Factorial Design, Publisher Gadjah Mada University, Yogyakarta.

